

Creation of Situational Awareness for Emergency Response and Management Using Next Generation Gigabit Communication Systems

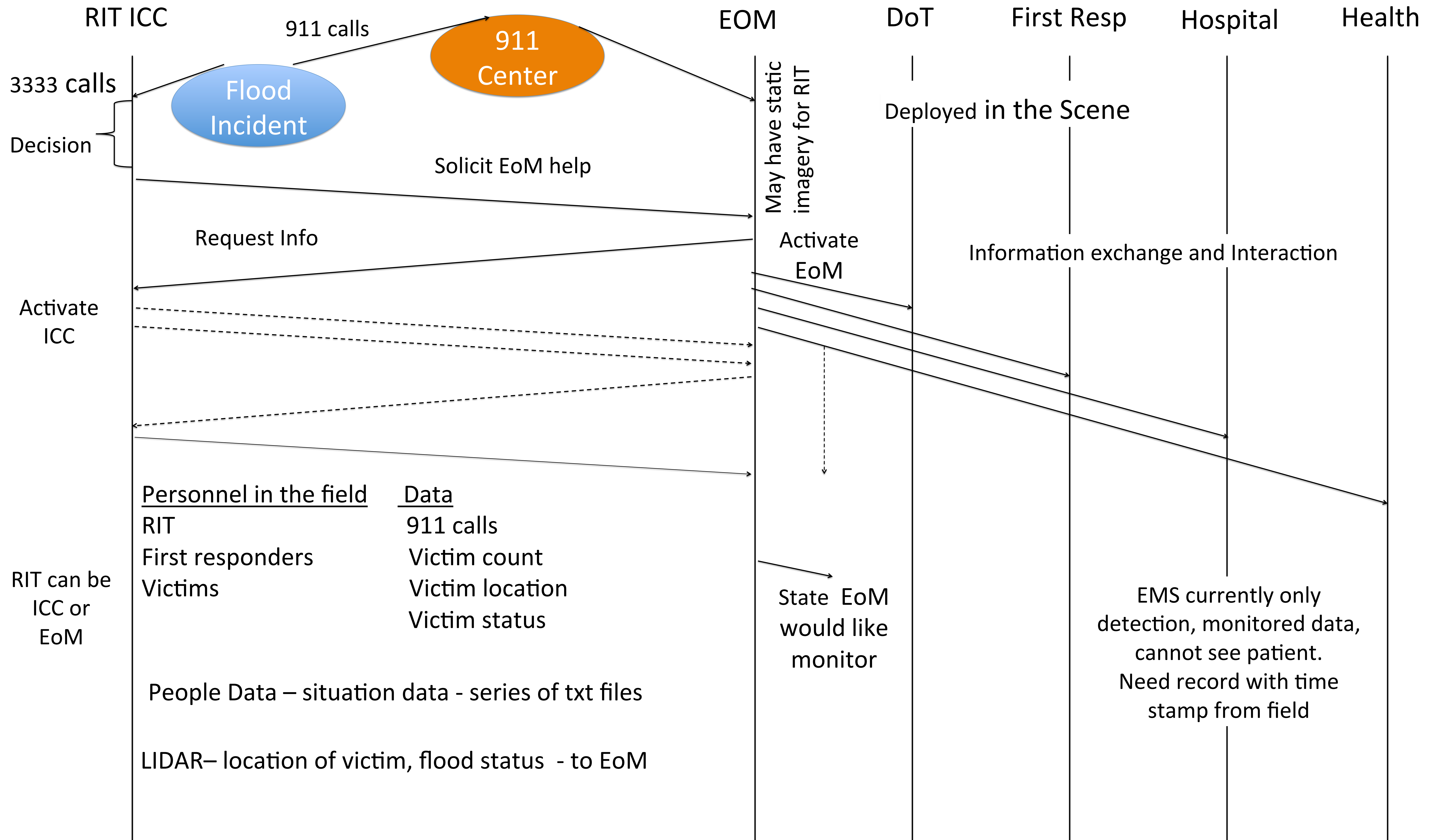

Emergency Data - Routing and Forwarding in the Internet – Using Gigabit Communication Systems

CONCERNS: Internet Protocol (IP), dependency on Border Gateway Routing Protocol, Internet Traffic, Route Failure Recovery, Route Instability

SOLUTION: Tunnel emergency traffic at layer 2.5, independent from IP and Routing Protocols

STAGE 1

Tiered Routing Protocol at Layer 2.5:
Routers route using Tiered Addresses – derived from ISP tiered model. Bypass IP and Routing protocol dependency.

Router F {2.2:1}					
Up-link		Down-Link		Trunk-Link	
Port	Dest	Port	Dest	Port	Dest
1	1.2	3	3.2:1:1	2	2.2:2 2.3:3

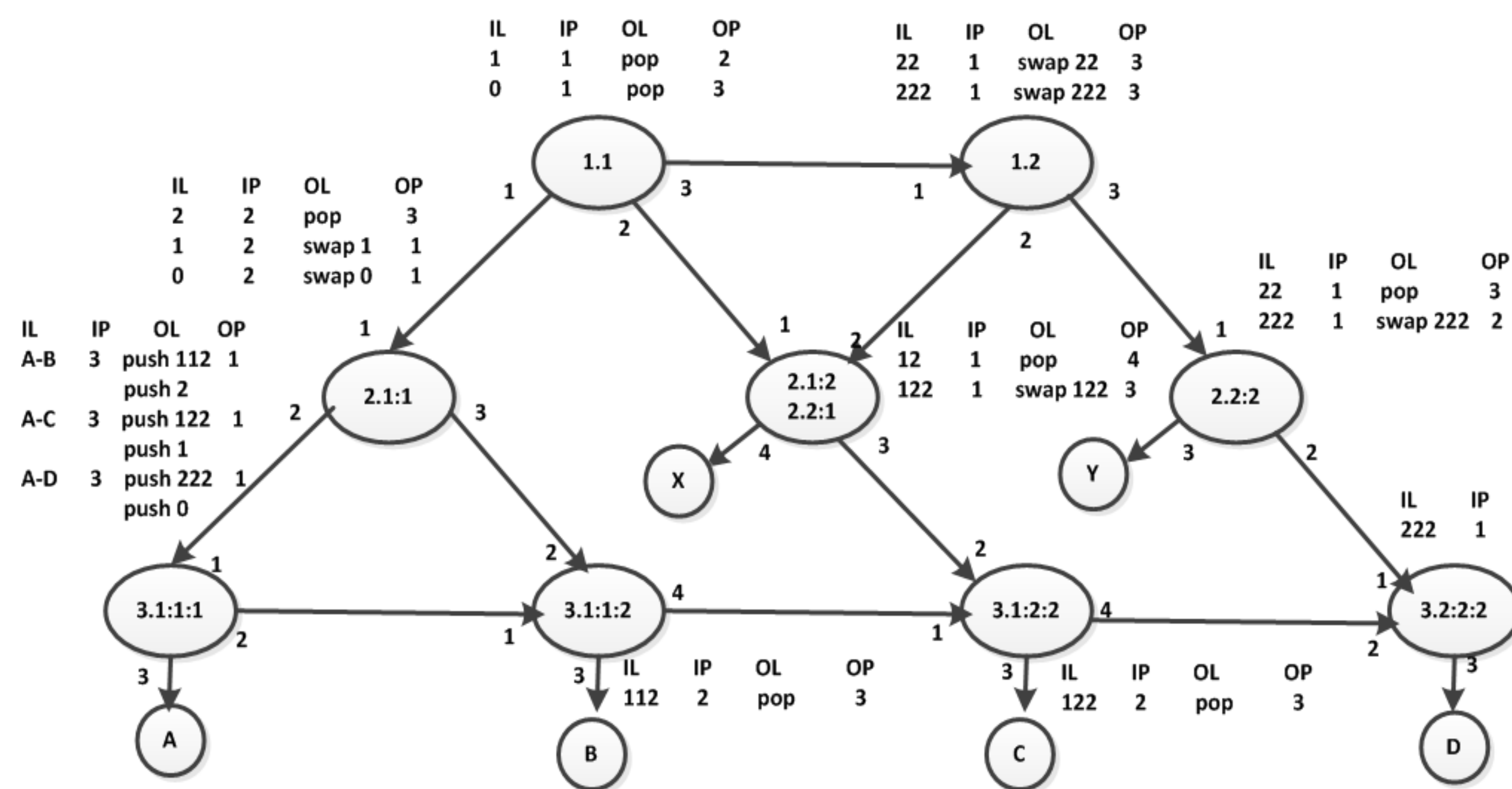
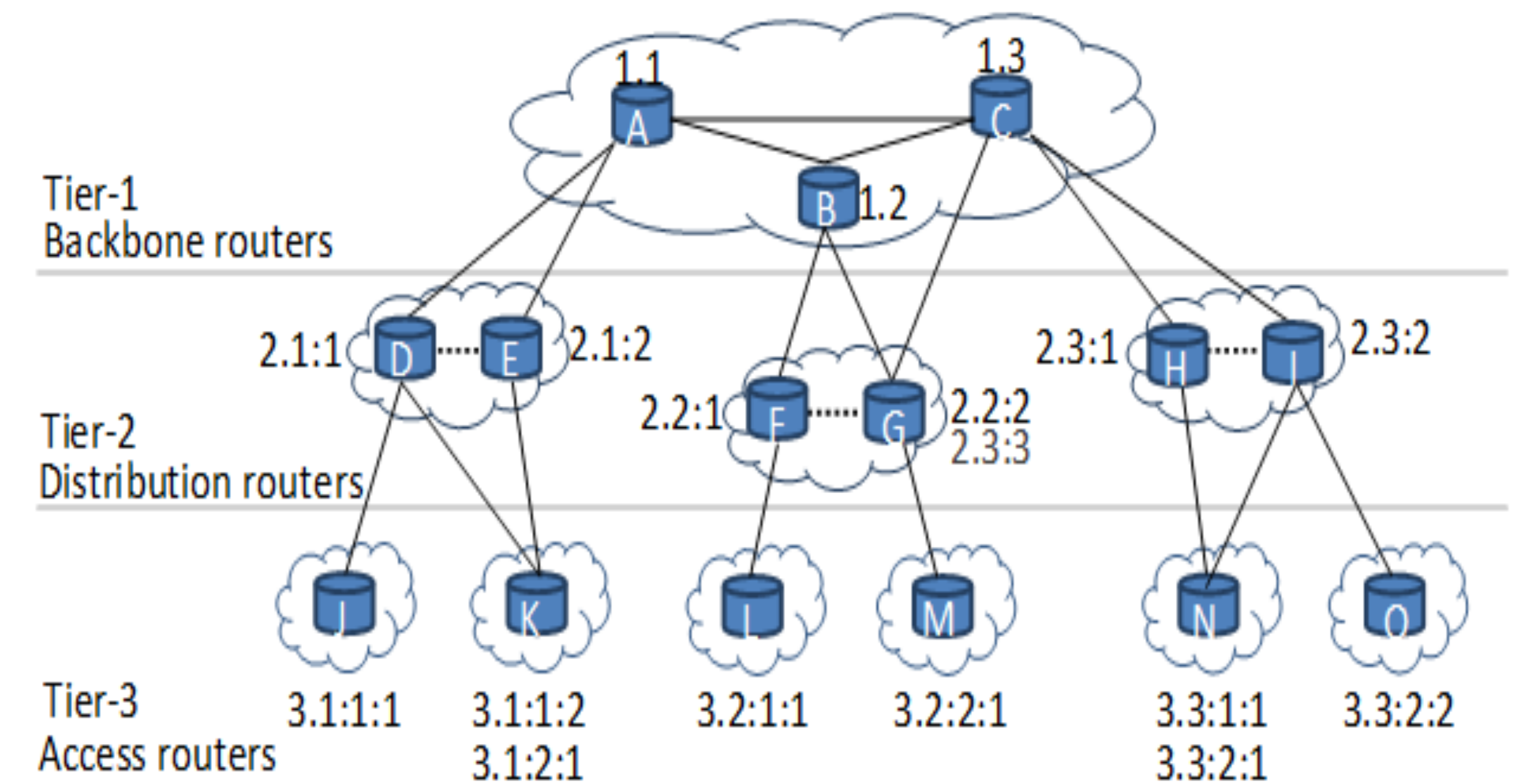

STAGE 3

MPLS a Routing Protocol? : Assign labels to nodes. Labels carry forwarding information. Advertise labels and populate a label table. Learn end network address at the edge of MPLS domain.

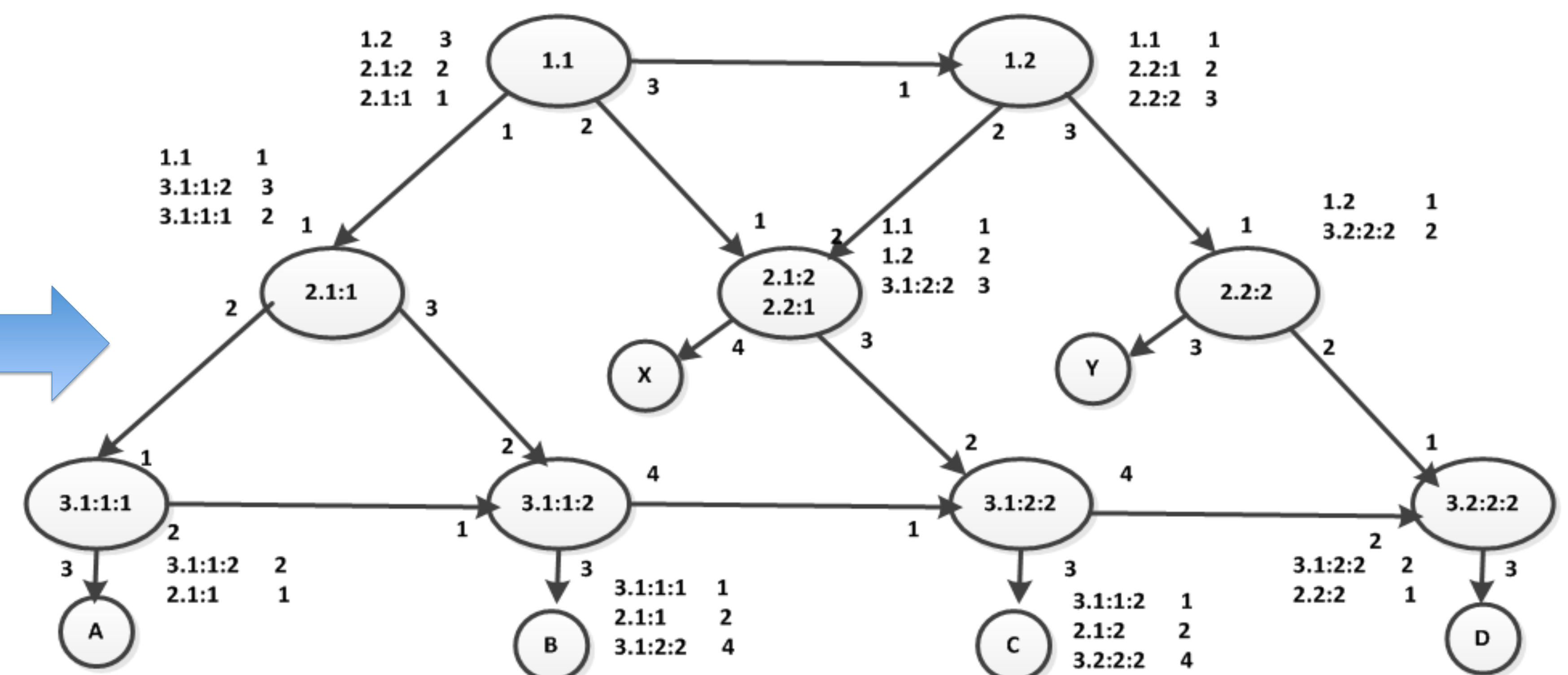

STAGE 2
MPLS Routing. Manual population of MPLS table. Tested MPLS on Linux systems in Emulab. Used IpRoute to populate MPLS table