

# **GENI**

Global Environment for Network Innovations

## **Milestone S2.e Design and Demo XML Data Exchange Software Modules**

Document ID: ERM\_S2d\_Aug10

August 31, 2010

Prepared by:

M.S. Wang, B.G. Bathula, C.P. Lai, C. Chen, and K. Bergman  
Dept. of Electrical Engineering, Columbia University New York,  
500 W. 120th Street,  
New York City, NY 10027  
under Project Nr. 1631

“Embedding real-time measurements for cross-layer communications”

## TABLE OF CONTENTS

1	DOCUMENT SCOPE .....	3
1.1	EXECUTIVE SUMMARY.....	3
1.2	RELATED DOCUMENTS .....	3
1.2.1	GENI Documents .....	3
1.3	DOCUMENT REVISION HISTORY.....	3
2	PREVIOUS WORK (SUMMARY OF MILESTONES S2.A, S2.B, S2.C, AND S2.D) .....	5
3	CONNECTING UMF WITH SILO .....	6
4	DEMO USE-CASE .....	6
5	EXPERIMENTAL RESULTS .....	8
6	SUMMARY AND CONCLUSION .....	9
7	BIBLIOGRAPHY .....	9

## 1 Document Scope

This section describes this document's purpose, its context within the overall GENI project, the set of related documents, and this document's revision history.

### 1.1 Executive Summary

This technical note presents the outcome of the work package Milestone S2.e of Project Nr. 1631, "Embedding real-time substrate measurements for cross-layer communications." This milestone document comprises the fifth deliverable of ERM in Spiral 2 and involves designing the XML data exchange software modules for the UMF to interact with the researcher or intermediate measurement software architecture (e.g. SILO, perfSONAR, etc.), and then to demonstrate the interoperability of these software modules with BEN at RENCI.

The goal is to integrate UMF with the SILO framework to enable cross-layer communication and control based on optical layer performance. To this end, we developed an XML-RPC-based software module within the UMF. This module enables SILO to communicate with UMF through a set of predefined API functions, thereby enabling cross-layer communication.

In Section 2, we summarize our previous work in milestone S2.a, S2.b, S2.c. and S2.d. In Section 3, we explain how UMF is connected to SILO. In Section 4, we describe the experimental use-case that demonstrates the interoperability of the UMF and SILO. Section 5 presents the experimental results. Section 6 gives a summary and conclusion.

### 1.2 Related Documents

The following documents are related to this document, and provide background information, requirements, etc., that are important for this document.

#### 1.2.1 GENI Documents

Document ID	Document Title and Issue Date
ERM_S2a_Dec09	Spiral 2 Milestone 2.a Technical Note
ERM_S2b_Mar10	Spiral 2 Milestone 2.b Technical Note
ERM_S2c_June10	Spiral 2 Milestone 2.c Technical Note
ERM_S2d_Aug10	Spiral 2 Milestone 2.d Technical Note

### 1.3 Document Revision History

The following table provides the revision history for this document, summarizing the date at which it was revised, who revised it, and a brief summary of the changes. This list is maintained in chronological order so the earliest version comes first in the list.

---

Revision	Date	Revised By	Summary of Changes
1.0	30 Aug 10	M. S. Wang	Initial draft

## 2 Previous Work (Summary of Milestones S2.a, S2.b, S2.c, and S2.d)

The goal of milestone S2.a [erm\_1] involved the design and development of UMF, which serves as a means for gathering physical-layer measurements and conveying the data to the GENI researcher in an aggregated, unified way. Design considerations were taken into account so that the UMF could be integrated within the ORCA cluster, initially, and then extended to other GENI control frameworks in the future. Further, we discussed an implementation of the UMF by means of a NetFPGA Cube [netfpga\_1], which is an integrated system composed of a general purpose processor, in addition to the proprietary NetFPGA hardware [netfpga\_2]. The UMF comprises of both a software component (implemented on the general purpose processor), as well as a hardware component (implemented on NetFPGA card). Each component has a defined role in facilitating the UMF to access the networking elements and its measurement data.

Further, the goal of milestone S2.b [erm\_2] involved implementing and demonstrating a working software interface between the UMF and at least one subsystem that is capable of embedded physical layer measurements, such as bit-error rate measurement or optical power monitoring. The specific subsystem we chose is a set of four Polatis switches within the ORCA-BEN [orca\_1] network, from which we retrieved the optical power. In doing so, we have merged our UMF design with the integrated measurement framework (IMF) [imf\_1] project implementation. By realizing the measurement handler (MH) for the Polatis switch and testing the functionality of the XMPP server and pubsub module (PSM), we demonstrated the ability of IMF to obtain real-time optical power measurements from any of the four Polatis switches in the ORCA-BEN network [orca\_1].

Then, the goal of milestone S2.c [erm\_3] involved demonstrating a working UMF prototype by implementing an experimental use-case at the Lightwave Research Laboratory at Columbia University. We set up a protected lightpath where the input signal can be switched to containing a semiconductor optical amplifier (SOA) if the input optical power is below a predefined threshold, and bypassing the SOA otherwise. We compared the eye diagrams and BER curves for the unprotected and protected paths while changing the attenuation of the input signal using a variable optical attenuator (VOA). For the same attenuation, we examine a more open eye diagram and lower BER for the protected path versus the unprotected path.

The goal of milestone S2.d [erm\_4] involved contributing to the cluster D effort by integrating the UMF subsystem with the Cluster D network substrate. More specifically, we integrated the developed hardware and software resources of UMF to the BEN infrastructure at the RENCi Point-Of-Presence (PoP).

### 3 Connecting UMF with SILO

After the UMF was physically integrated into the BEN network in milestone S2.d, the next step is to connect UMF to the SILO framework. The UMF is implemented on a NetFPGA Cube system [netfpga\_1], [netfpga\_2]. It comprises of both a software component (using the general purpose processor), as well as a hardware component (using the NetFPGA card) [erm\_1]. Fig 3.1 shows the architectural block diagram of the UMF.

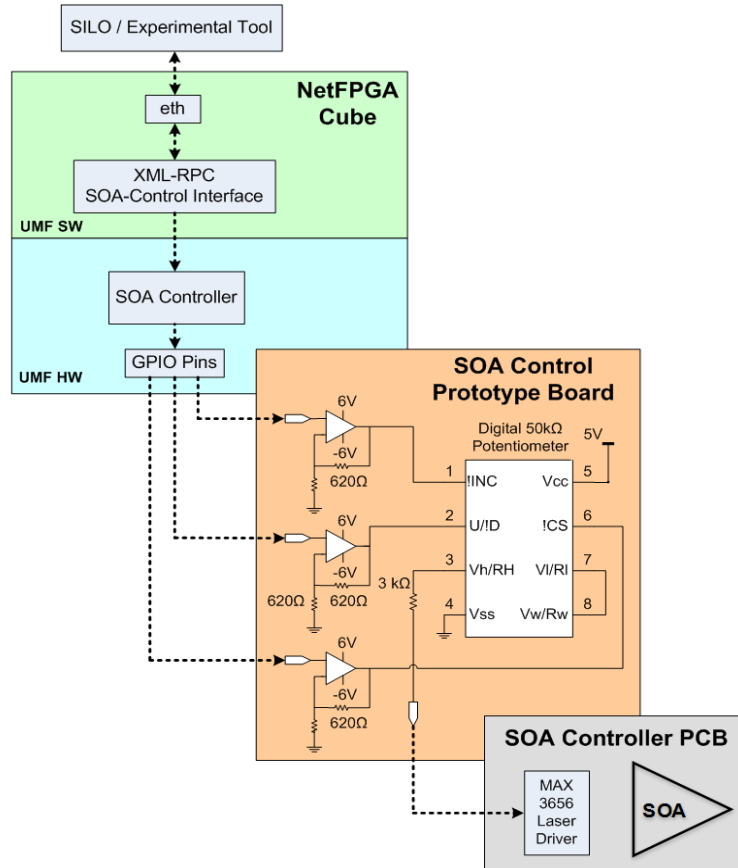
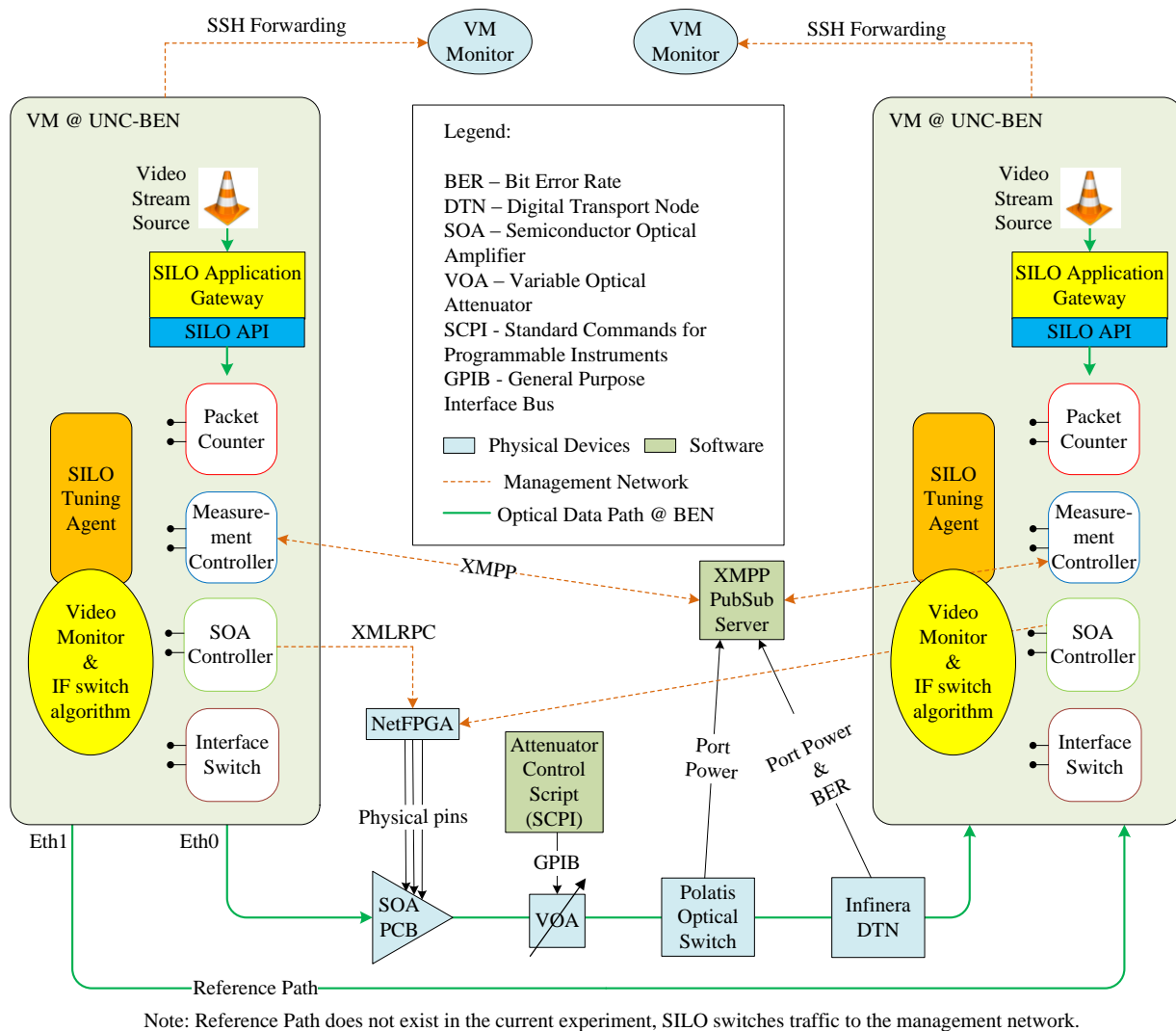

**Fig 3.1 UMF Architecture**

The UMF SW consists of the XML-RPC-based software module code, which is used to communicate with SILO or other experimental tools to enable cross-layer communication and control. This software module contains a set of predefined API functions that SILO can call to control a SOA. The SOA resides on a printed circuit board (PCB) that contains a laser driver. The gain of an SOA is controlled by the amount of current driven to it. This laser driver is connected to a digital potentiometer, which is housed on the SOA Control Prototype Board. This potentiometer is used to vary the current in the current driver. The XML-RPC-based software module can control the UMF HW to vary the gain of the SOA, based on the commands from SILO, thereby enabling cross-layer control.

### 4 Demo Use-Case

Figure 4.1 shows the experimental setup used to demonstrate the interoperability of SILO and UMF.



**Fig 4.1 Experimental Use-Case**

The goal of this demonstration is to showcase the ability to run a streaming digital media application across BEN. Combining the efforts of IMF [imf\_1], ERM, and SILO, we aim to demonstrate cross-layer communication among various layers of the Internet protocol stack, from the application layer to the optical physical layer. GENI provides the unique ability to run a real application on a network that supports cross-layer communication at various layers. More specifically, we streamed a video across BEN while adjusting the physical layer. By introducing a controlled error into the network, we have shown the benefits of cross-layer communication.

Fig 4.1 shows the setup of the experiment at BEN. A video is streamed from UNC and RENC1. When the cross-layer signaling is turned on, it ensures that the video is sent above a guaranteed optical power threshold, even when there is power fluctuation in the physical channel. When the cross-layer signaling is turned off, we see a dramatic degradation in video quality. By comparing the video qualities at the receiving end, we showcase the advantages of our cross-layer communication design.

The applications sending and receiving the videos at UNC and DUKE will be monitored by the SILO framework. SILO can detect the video stream's priority via certain services, and tune the SOA controlled by UMF to ensure the quality of the video stream.

Moreover, the RENC1 PoP will contain a set of components that will enable cross-layer communication specifically between the physical layer and the higher layers as defined by SILO:

- Polatis switch – This optical switch will measure the optical power of the data received from UNC.
- Programmable attenuator – This is used to lower the power of the received signal. As the power of the signal carrying the video stream decreases, the more errors there will be in the transit video stream. This gives us the ability to introduce a repeatable error into the network.
- SOA – This is used to amplifier the power of an optical signal. It is controlled by a NetFPGA-based UMF.

## 5 Experimental Results

Figure 5.1(a) shows the power level of the link without cross-layer compensation. The range of power fluctuation is 11 dB (between -11 to -22 dBm). This is the attenuation that is set by the programmable attenuator.

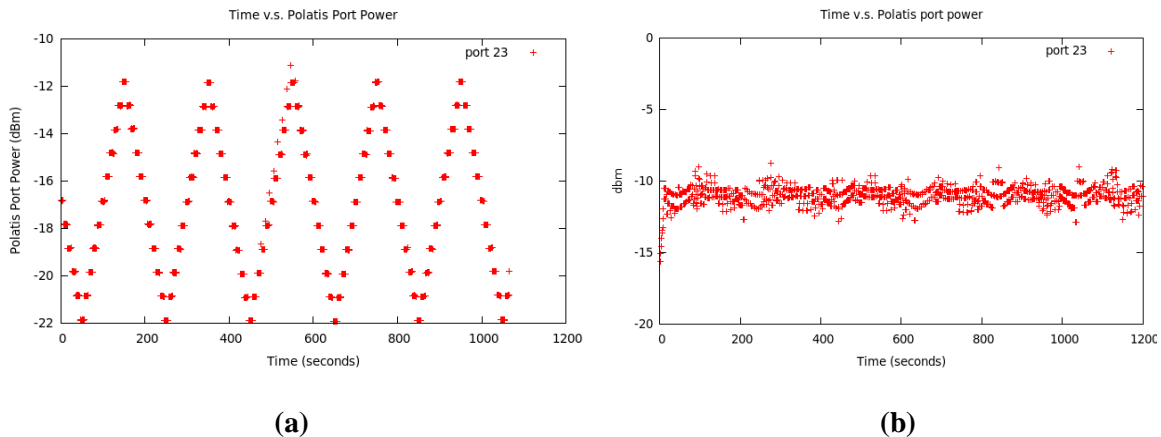

**Fig 5.1 (a) power level w/o cross-layer compensation**  
**(b) power level with cross-layer compensation**

Figure 5.1(b) shows the power level of the link with cross-layer compensation turned on. In this case, the power level is ensured to always fall within a smaller range of fluctuation. The full range of power fluctuation is around 5 dB (b/w -10 to -15 dBm) most of the time.



## 6 Summary and Conclusion

This milestone involved designing the XML data exchange software modules for the UMF to interact with the researcher or intermediate measurement software architecture (e.g. SILO, perfSONAR, etc.), and then to demonstrate the interoperability of these software modules with BEN at RENCI. To this end, we developed an XML-RPC-based software module within the UMF. This module enables SILO to communicate with UMF through a set of predefined API functions, thereby enabling cross-layer communication. We demonstrated the interoperability of SILO and UMF by demonstrating a cross-layer optimized digital media streaming application across BEN.

## 7 Bibliography

- [1] [lrl\_1] Lightwave Research Laboratories. [Online]. Available: <http://lightwave.ee.columbia.edu/>
- [2] [netfpga\_1] NetFPGA Cube main homepage. [Online]. Available: [http://www.accenttechnologyinc.com/netfpga.php?category\\_id=0&item\\_id=1](http://www.accenttechnologyinc.com/netfpga.php?category_id=0&item_id=1)
- [3] [netfpga\_2] NetFPGA website. [Online]. Available: <http://www.netfpga.org/>
- [4] [erm\_1] C. P. Lai, M. S. Wang, and K. Bergman, "Unified Measurement Framework: NetFPGA Prototype (Project Nr. 1631, Milestone S2.a)," (2009, Dec) [Online]. Available: <http://groups.geni.net/geni/wiki/Embedded%20Real-Time%20Measurements>
- [5] [erm\_2] M. S. Wang, C. P. Lai, and K. Bergman, "Demonstrating Embedded Real-Time Physical Measurement from ORCA-BEN Substrate (Project Nr. 1631, Milestone S2.b)," (2010, Mar) [Online]. Available: <http://groups.geni.net/geni/wiki/Embedded%20Real-Time%20Measurements>
- [6] [erm\_3] M.S.Wang, B. Bathula, C.P.Lai, and K. Bergman, "Demo UMF in an Experimental Use-Case (Project Nr. 1631, Milestone S2.c)," (2010, June) [Online]. Available: <http://groups.geni.net/geni/wiki/Embedded%20Real-Time%20Measurements>
- [7] [erm\_4] M.S.Wang, B. Bathula, C.P.Lai, C. Chen, and K. Bergman, "Integrate UMF with BEN (Project Nr. 1631, Milestone S2.d)," (2010, August) [Online]. Available: <http://groups.geni.net/geni/wiki/Embedded%20Real-Time%20Measurements>
- [8] [orca\_1] ORCA main homepage. [Online]. Available: <http://nicl.cod.cs.duke.edu/orca/>
- [9] [imf\_1] GENI IMF Wiki. [Online]. Available: <http://groups.geni.net/geni/wiki/IMF>
- [10] [polatis\_1] Polatis main homepage. [Online]. Available: <http://www.polatis.com/>